



1-800-779-2102

Mon – Thurs: 8:00am - 5:00pm | Friday: 8:00am - 4:00pm CST

INSPECT YOUR PRODUCT FOR DAMAGE & MISSING PARTS BEFORE PROCEEDING TO INSTALLATION

PROCEDURE FOR RETURNS OR MISSING HARDWARE

-PLEASE CONTACT THE ORIGINAL POINT OF PURCHASE FOR:
SHIPPING DAMAGE, RETURNS, OR WARRANTY CLAIMS

-CONTACT DEE ZEE DIRECTLY FOR MISSING PARTS OR HARDWARE

WWW.DEEZEE.COM

REGISTER YOUR PRODUCT ONLINE: www.deezee.com/registration

VIEW INSTRUCTIONS ONLINE: www.deezee.com/instructions

⚠️ WARNING: Cancer and Reproductive Harm
www.P65Warnings.ca.gov

Operating, servicing, and maintaining a passenger vehicle can expose you to chemicals such as lead, phthalates, engine exhaust, and carbon monoxide that are known to the State of California cause cancer and birth defects or other reproductive harm. To minimize exposure, service your vehicle and its accessories in a well-vented area and wear gloves or wash your hands frequently.



DEE ZEE, INC. WARRANTY AGREEMENT

Dee Zee, Inc. guarantees the original purchaser a limited lifetime warranty against manufacturer defects in materials, workmanship, and design under normal use, excluding damage resulting from road hazards such as gravel or other debris, product misuse, improper installation, impairments from accidents, product modifications, improper repairs, spills, vandalism, product neglect, or acts of God.

This warranty applies only to the original purchaser of new product(s) and is limited to the replacement of genuine Dee Zee products. Modification of any kind to Dee Zee products voids all warranty coverage. Warranty does not include electrical components, installation, cost of removal, labor, transportation costs, loss of use, inconvenience, or consequential damages.

WARRANTY COVERAGE - MATERIALS & WORKMANSHIP

LIMITED LIFETIME WARRANTY:

- STAINLESS STEEL: Side Steps, Grill Guards, Bull Bars, Bed Caps, and Side Rails
- ALUMINUM: Side Steps, Running Boards, Storage Boxes, Transfer Tanks, Bed Protection, Side Rails, Invis-A-Racks, and Cab Racks
- PLASTIC: Storage Boxes
- OTHER: Front and Rear Bumpers

THREE-YEAR WARRANTY:

- POWDER-COATED / E-COATED STEEL: Side Steps, Running Boards, Storage Boxes, Transfer Tanks, Cab Racks, Sport Bar Ladder Racks, Cargo Carriers, Mounting Brackets (NX, Rough Step, and Bumper Guards only)
- OTHER: Tailgate Assist, Bed Mats, Floor Mats, Auxiliary Fuel Connection Kits, and All Products Not Otherwise Listed Individually

WARRANTY COVERAGE – FINISH PROTECTION

The finish of all Dee Zee products is covered for one-year (1) from the date of purchase. Dee Zee products have a high quality finish that must be cared for and maintained like any other exposed finish on the vehicle. Protect the finish with non-abrasive automotive wax (e.g. Pure Carnauba) on a regular basis. Applying soaps, polishes, or waxes that contain an abrasive compound may scratch the finish and leave the exposed material susceptible to corrosion.

WARRANTY COVERAGE – COMPONENT PARTS

Operational items such as shocks, latches, hinges, and wear items including, but not limited to, mud flaps, step pads, toolbox tray, end caps, hardware, seals, etc. have a one-year (1) warranty. Replacement component parts can be ordered via credit card (MasterCard or VISA) by calling 1-800-779-2102. All replacement parts are non-returnable and non-refundable.

GPI® FUEL PUMPS & ACCESSORIES

All Great Plains Industries (GPI) products, including transfer tank pumps and fuel meters are covered by GPI's warranty policies. Dee Zee's warranty terms do not apply to GPI products. To submit a warranty claim, please contact GPI at 1-800-835-0113 or visit www.gpi.net.

WARRANTY SUBMISSION PROCEDURE

All warranty claims will be initiated at the place of purchase. The original purchaser will be required to present the original sales receipt with purchase date shown and provide photographs of the defect.

In the event the originally purchased product style is no longer available, Dee Zee will warranty the defective part with a current equivalent. If a comparable product is no longer available, the product would be returned to the store of purchase for a refund or the applicable cost difference can be paid to choose an alternate style.

DISCLAIMER

All products are sold as appearance accessories and should not be relied upon as protection for the vehicle or its occupants in the event of an accident. Vehicles equipped with a supplemental restraints system (air bags) deployed by impact and collision avoidance systems should not be modified in any way. Always consult the vehicle manufacturer if you have any questions regarding supplemental restraint systems and sensors.

Buyer must accommodate front and rear sensors during product installation and assumes all risk should these be tampered, rerouted, severed, or disconnected. This includes disabling visual, audio, or vibration alerts into the cab. Buyer assumes all risk and responsibility for wiring any supplemental auxiliary lights.

Buyer assumes all risk, liability, and cost for the installation and use of Dee Zee products. Dee Zee, Inc. assumes no liability for injury, loss, incidental or consequential damages in the event of an accident.



Thank you for choosing Dee Zee to add function and accessorize your vehicle. Dee Zee has been a staple brand in the truck accessory market since 1977 and we hold a reputation of quality manufacturing based in America's Heartland. Our products are born through careful engineering and backed by industry leading warranty programs. We appreciate the opportunity to serve you and your vehicle!

Review the instruction pages in their entirety to prepare the required tools

Note: Review & assure understanding of all load, handling, operating limitations, and safety messages contained in your Vehicle Owner's Manual.

Warning: Invis-A-Rack load should never exceed **500 lbs.** and should always be evenly distributed & secured.

Ensure all fasteners & supports used to erect the front and rear crossbars of the Invis-A-Rack are fully engaged & secured. Inspect all connections frequently and do not use Invis-A-Rack if it is damaged or has been subjected to unintended overload.

Required steps to raise and stow the Invis-A-Rack involves pinch points where braces and cross pieces attach. Keep fingers clear and never attempt to set-up or stow with load on Invis-A-Rack.

Caution: All the included bed rail clamps must be secured to support Invis-A-Rack and its load. Check rail clamps regularly (particularly if rough road) and retighten as necessary.

Never use the bed rail claps as the attachment points for cargo straps or any other means of securing a load to avoid property damage, hazardous situations, or personal injury. Always secure loads down to factory (OEM) tie down locations in the truck bed.

Visit www.deezee.com to find additional anchor points for your truck bed.



Dee Zee Cares - Please Recycle

For an electronic version of these instructions visit: www.deezee.com/instructions

Register your product online: www.deezee.com/registration

INVIS-A-RACK INSTALLATION INSTRUCTION

DZ 951550, DZ 951600, DZ 951800

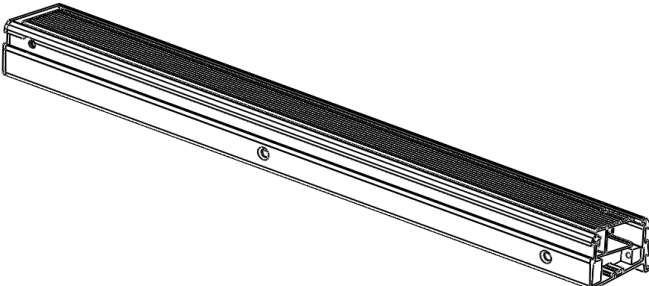
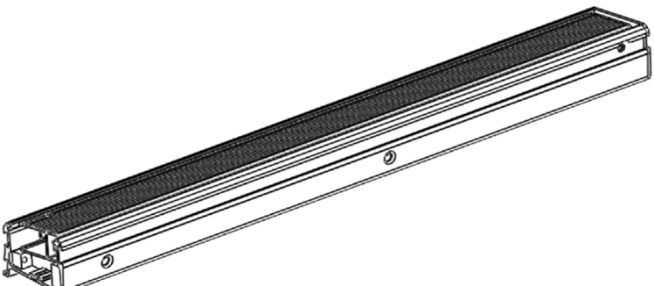
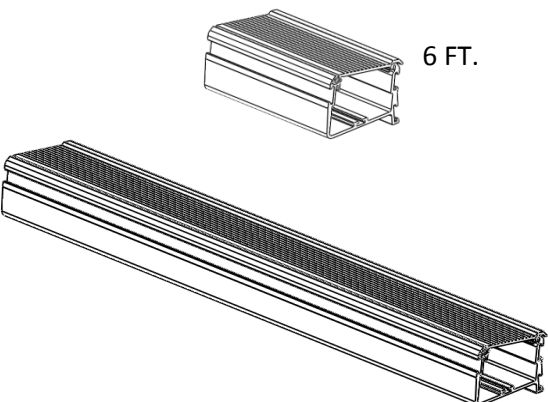
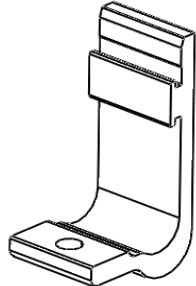
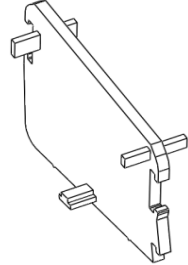
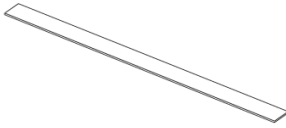
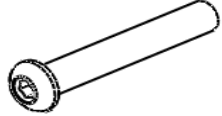
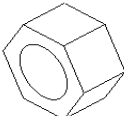
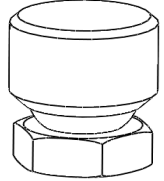
<p>A DRIVER FRONT / PASSENGER REAR</p>  <p>IR-HOUSING-ASSEML X2</p>	<p>B PASSENGER FRONT / DRIVER REAR</p>  <p>IR-HOUSING-ASSEMR X2</p>		
<p>C BUNGEE BOX</p> <p>THERE IS NO BUNGEE BOX IN THE 5 FT. APPLICATION</p>  <p>6 FT.</p> <p>8 FT.</p> <p>VARIES X2</p>	<p>D MOUNTING HOOK</p>  <p>DZE-539-150C X8</p>	<p>E SECTION CAP</p>  <p>ECIR4 X4</p>	
<p>F FOAM GASKET</p>  <p>FGT 32 16 FT.</p>	<p>G 3/8" BOLT</p>  <p>PN 220 X8</p>	<p>H 3/8" NUT</p>  <p>PN 90 X8</p>	<p>I SWIVEL</p>  <p>PN 1130 X8</p>

TOOLS REQUIRED

WRENCH
9/16"

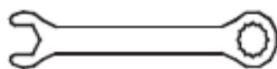

UTILITY KNIFE OR SCISSORS

7/32" ALLEN WRENCH OR SOCKET

RATCHET

- 1 Peel a portion of the paper back from the adhesive on the foam gasket [F].
Apply the sticky side of the gasket to the bottom of the rack assemblies and bungee boxes (if applicable).
Use the lip on the bottom side as a guide to apply the gasket straight with the part.

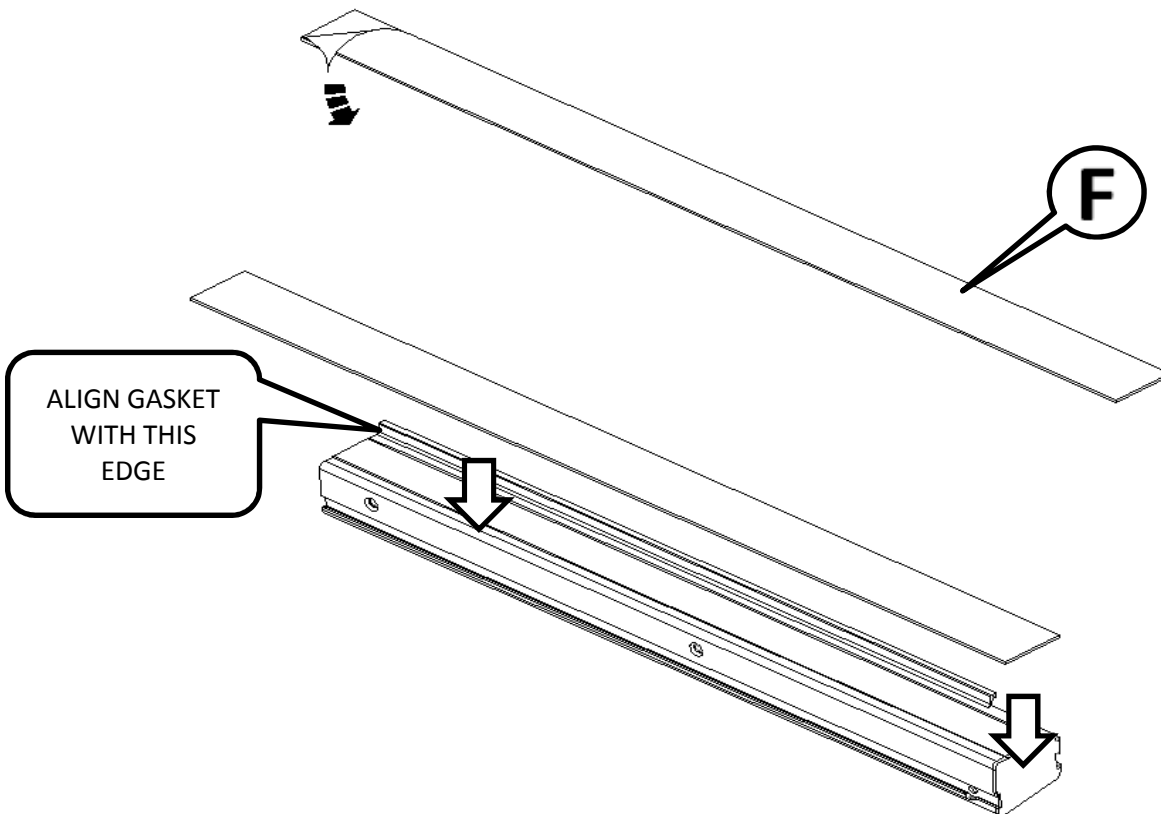

After applying the gasket, use a utility knife to trim the gasket with the end of the part.

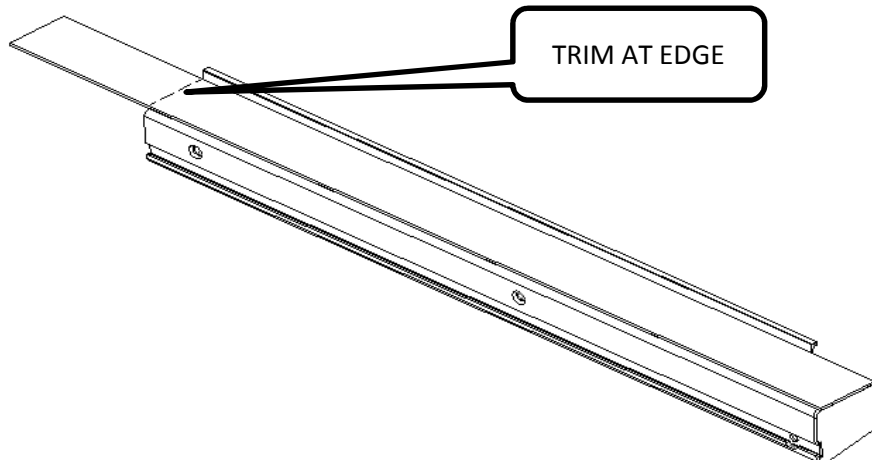

2

If your application includes bungee boxes, they will need to be assembled.

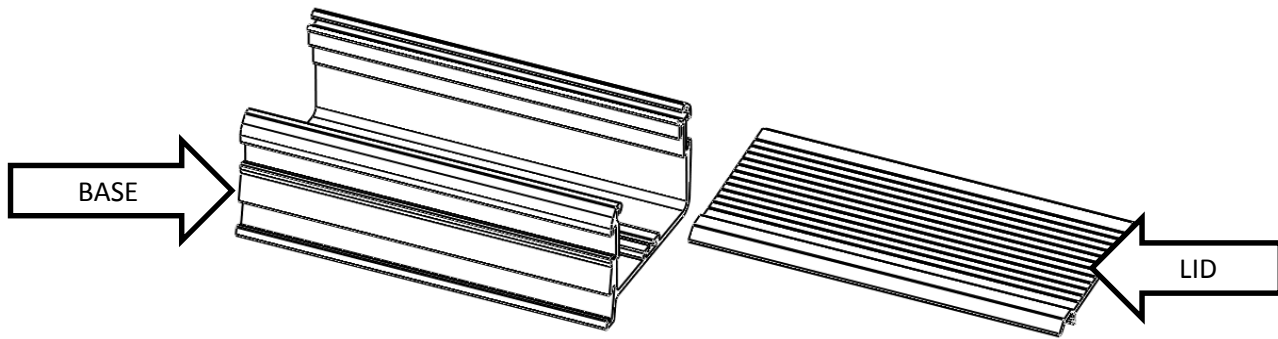

With the lid held almost perpendicular to the base, align the hook on the back of the lid with the channel on the base. Slide the lid onto the base.

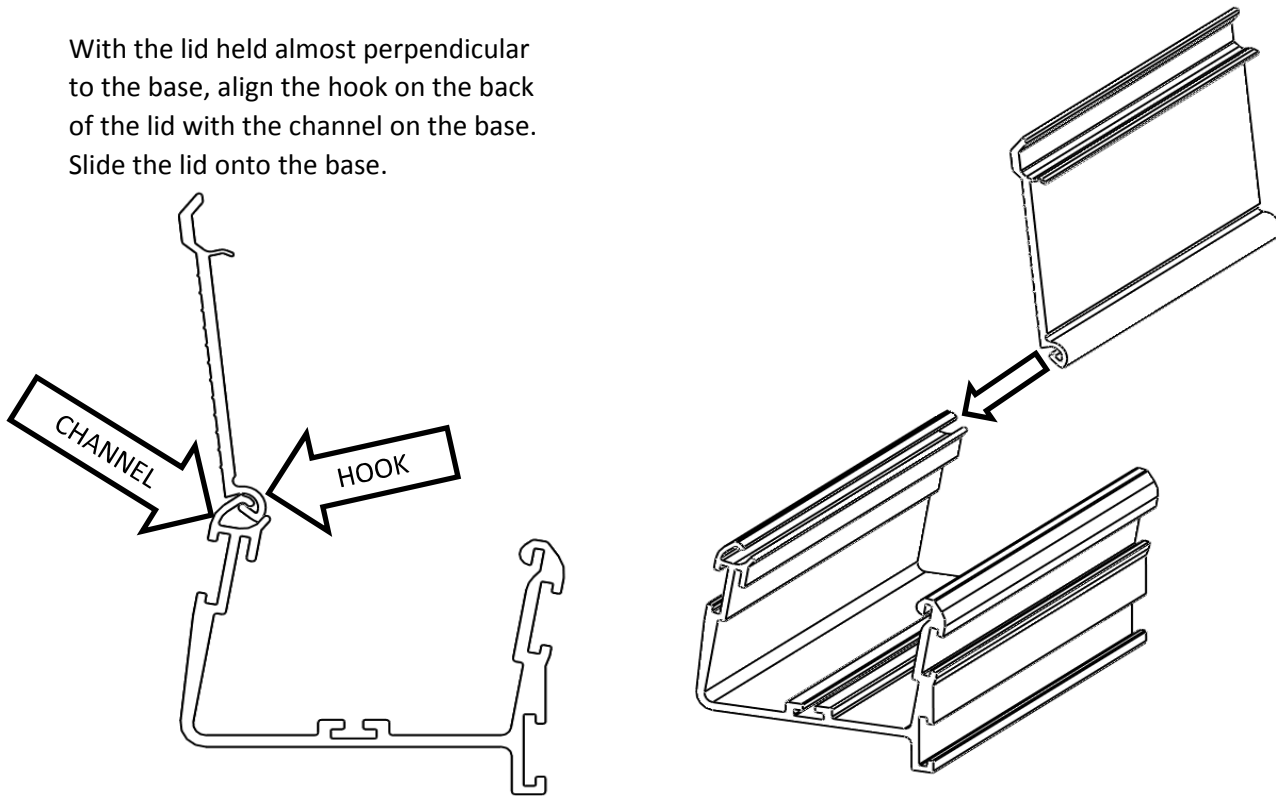

When the edges are flush, close the lid.

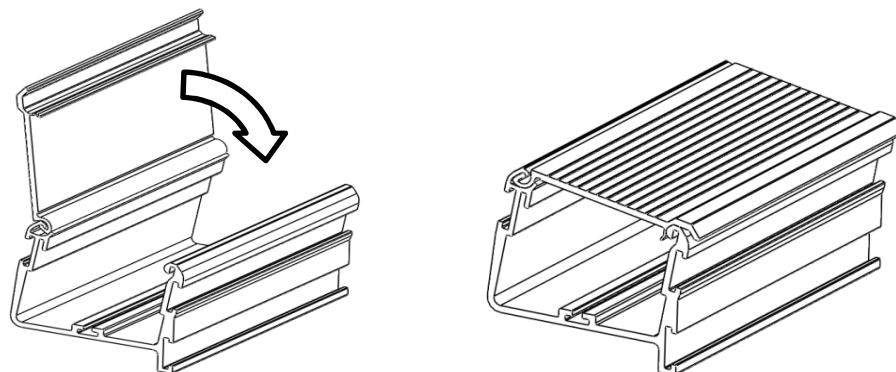

3 Set the first assembly [A] on the bed of the truck on the driver's side near the cab. This step is shown with the small bungee box for the 6' bed. If you are installing on a 5.5' bed, there will not be a bungee box, and you will only use one of the section cap [E] per side. If you are installing on an 8' bed, the bungee box will be longer than what is shown below, but will install in the same way. Assemble the sections as shown below.

The tabs in the section cap [E] fit into the extrusion as shown in this figure. When installed to outside profile of the section cap will match the extrusion profile.

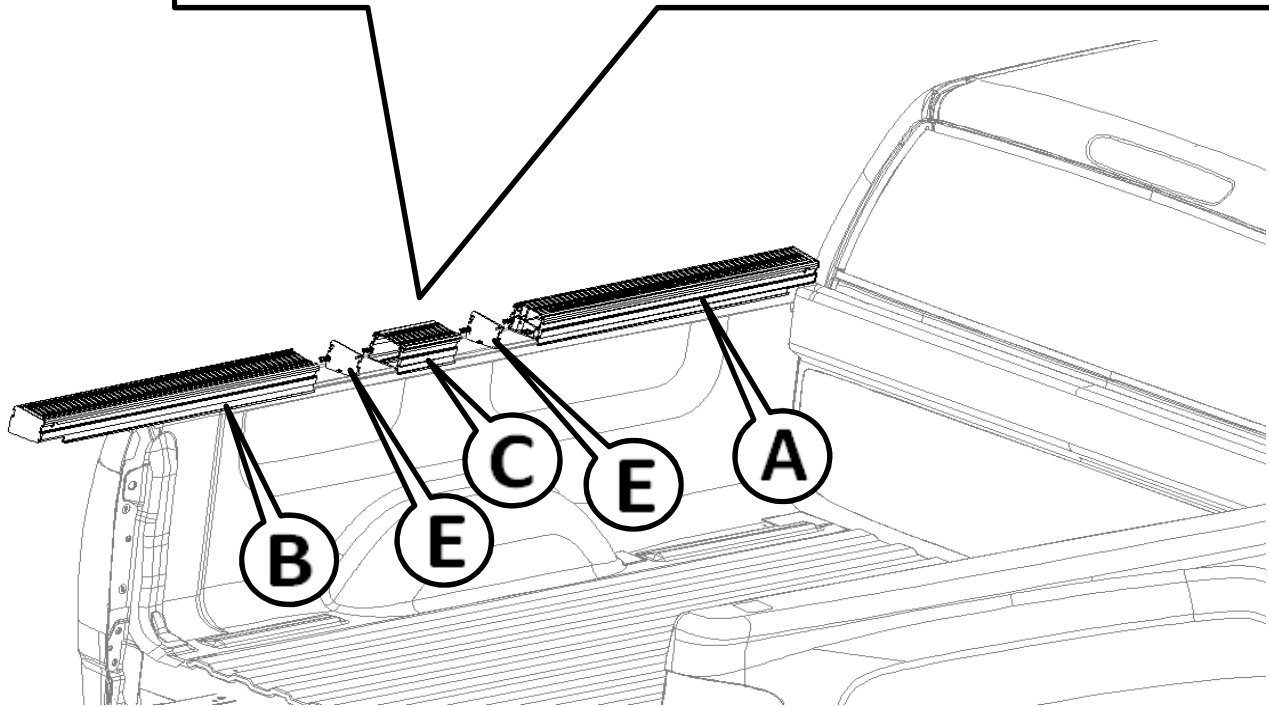
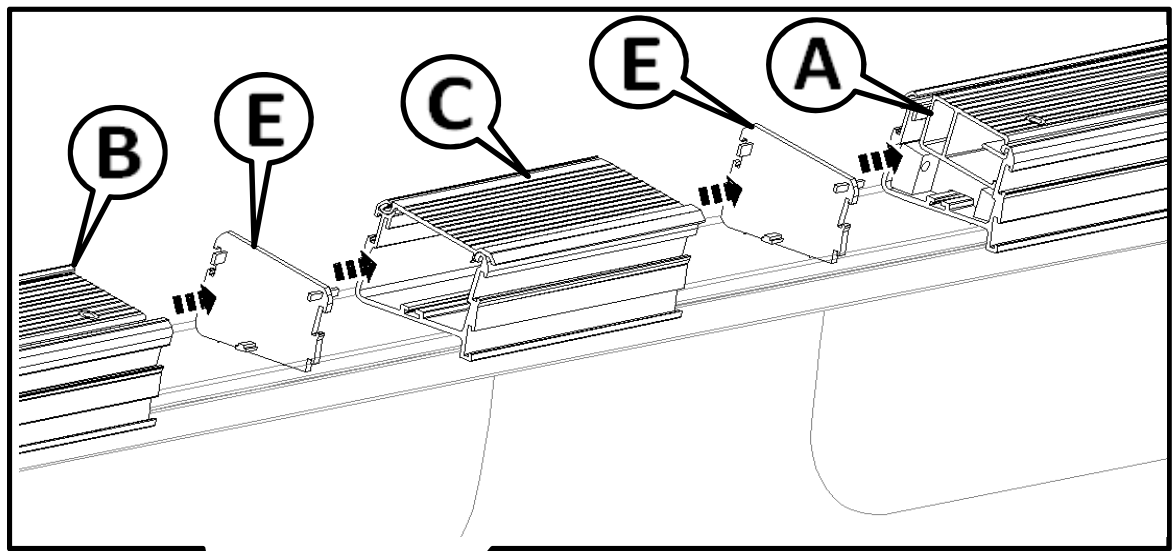
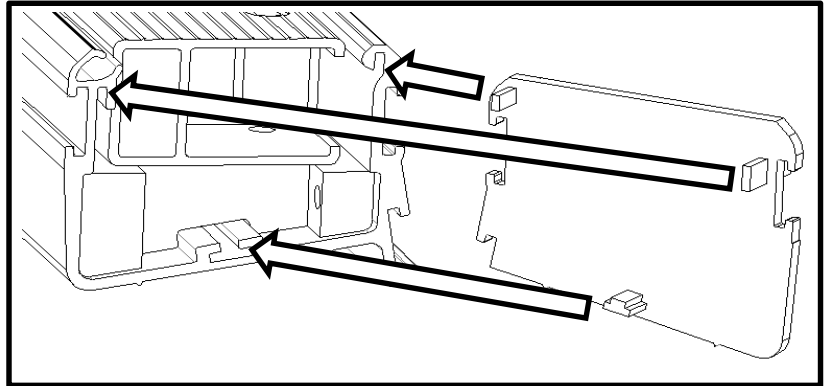

4

Thread one of the 3/8" nuts [H] onto the 3/8" bolt [G], then thread the bolt part way into the hole on the hold down clamp [D]. Then thread the swivel [I] onto the end of the bolt. There will be 4 of these used per side.

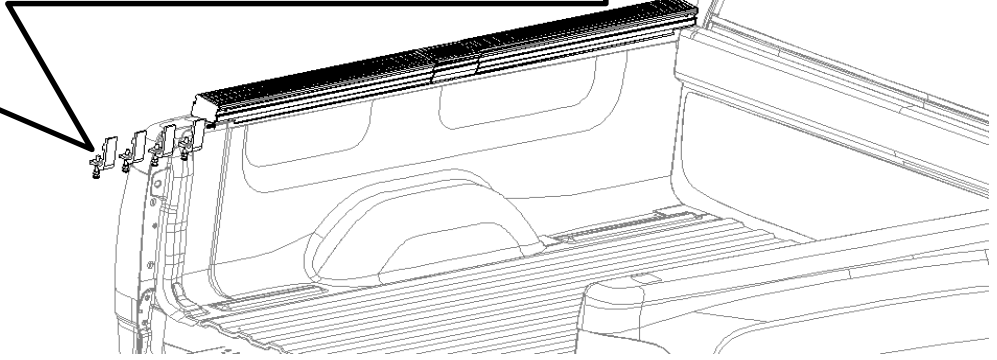
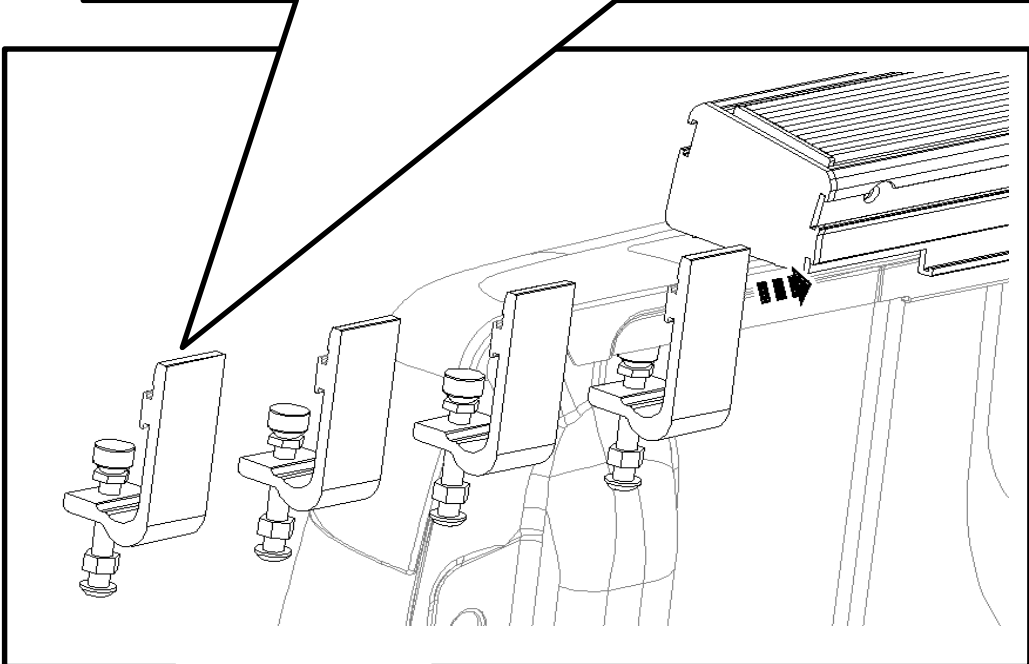
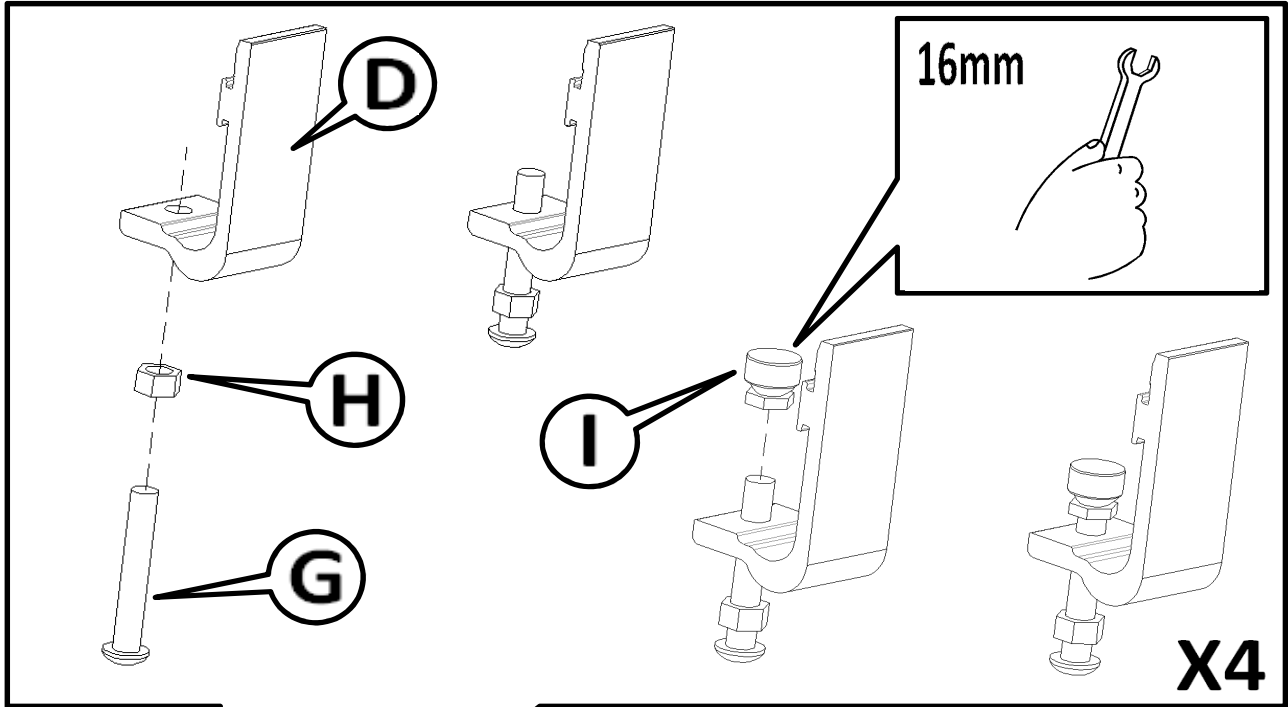

5

Use the images below to locate the hold down clamps for each truck bed length.

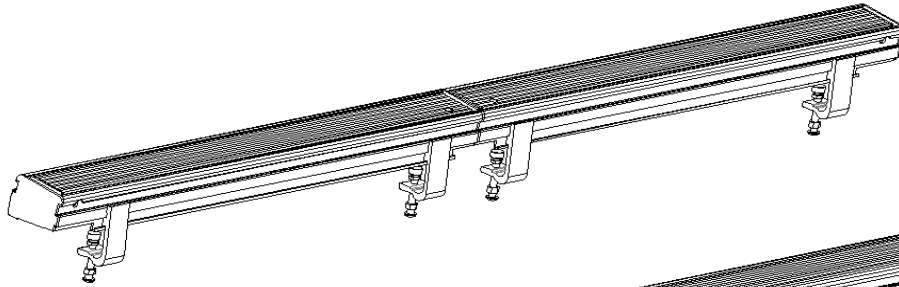

5.5' BED

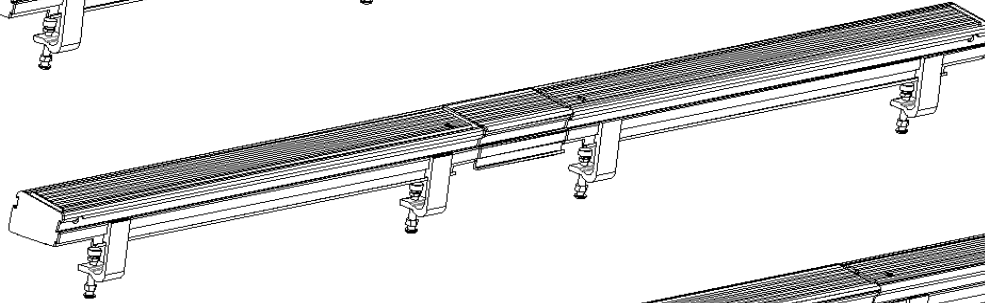

6' BED

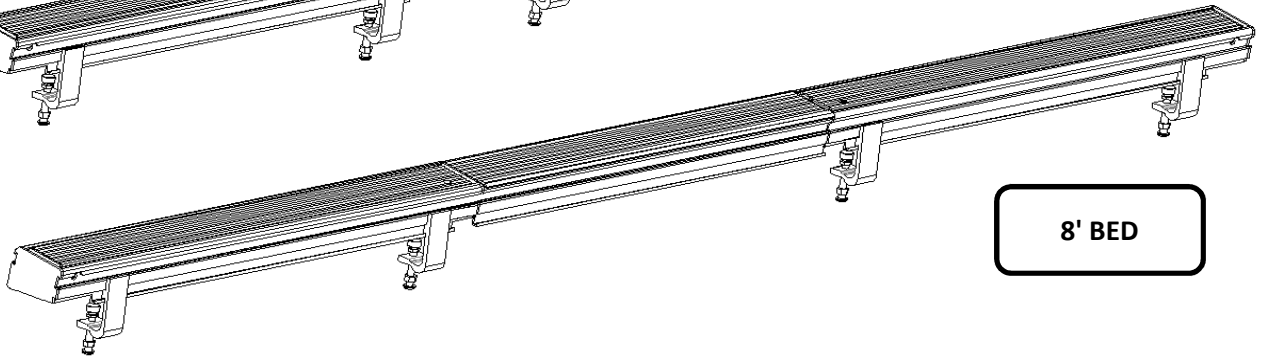

8' BED

The end hold down clamps should be as close to the end as the truck bed allows, but still completely in the channel of the extrusion.

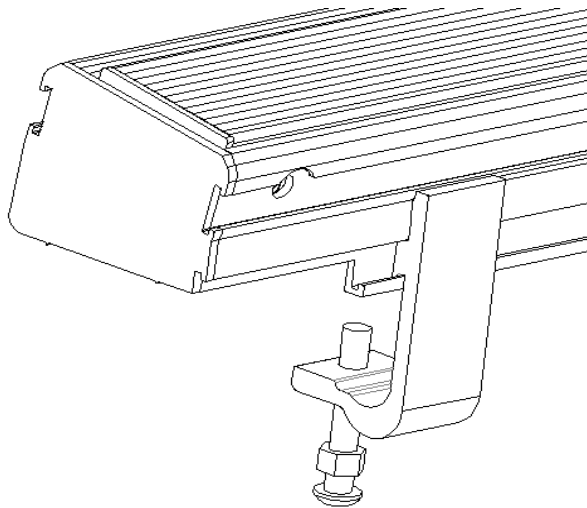

For applications with the bungee box, the hold down clamp needs to bridge the joint between the rack section and the bungee box equally.

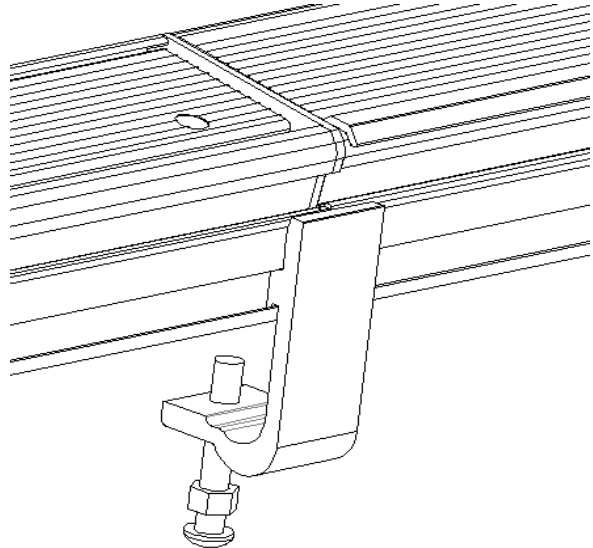

Note: Some trucks will have a center stake hole that will not allow the hold down clamp to bridge the joint of the main housing and bungee box. In this case, it is important to make sure that the two hold down clamps are installed on the front main housing and two hold down clamps are installed on the rear main housing (One as far forward as possible and one as far back as possible).

6 Tighten the bolts using a 7/32" allen wrench/socket. Start with the bolt closest to the cab and work your way to the bolt at other end of the bed. Repeat the process of tightening the bolts to insure that all are completely tighten.

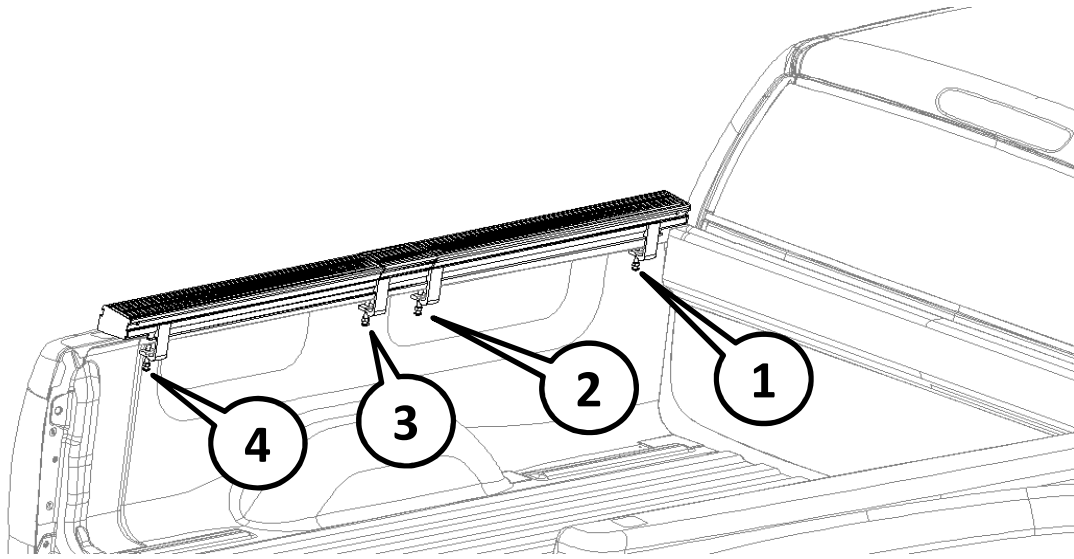

7 Once the 3/8" bolts have been tightened, using a 9/16" open end wrench, tighten the nut against the bottom of the hold down clamp.

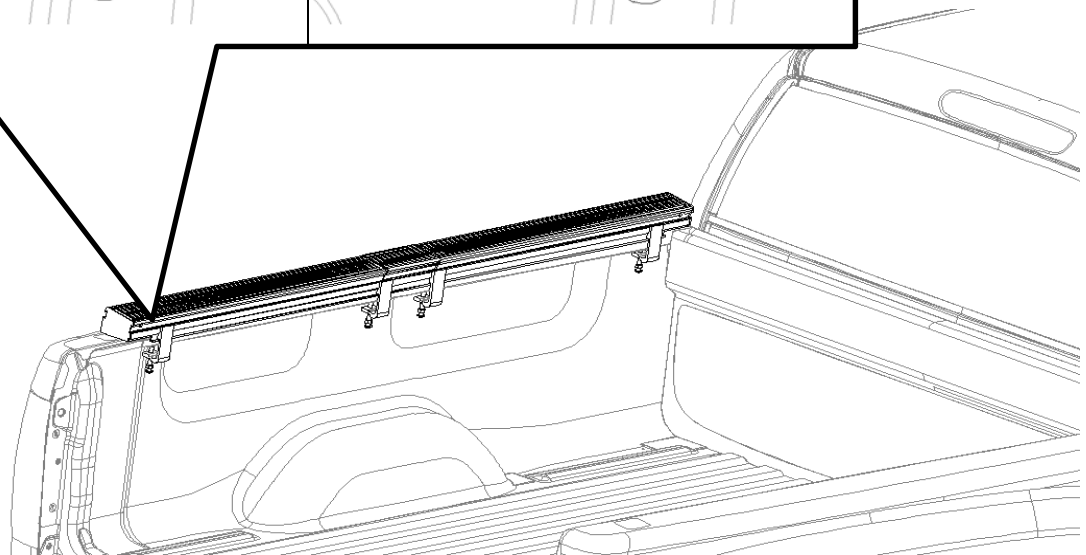
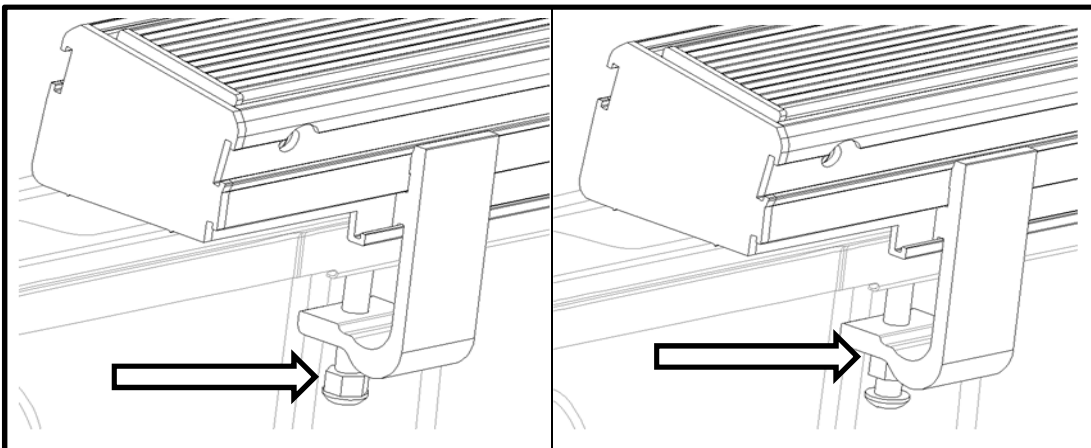

8

Repeat these installation steps for the other side of the bed.

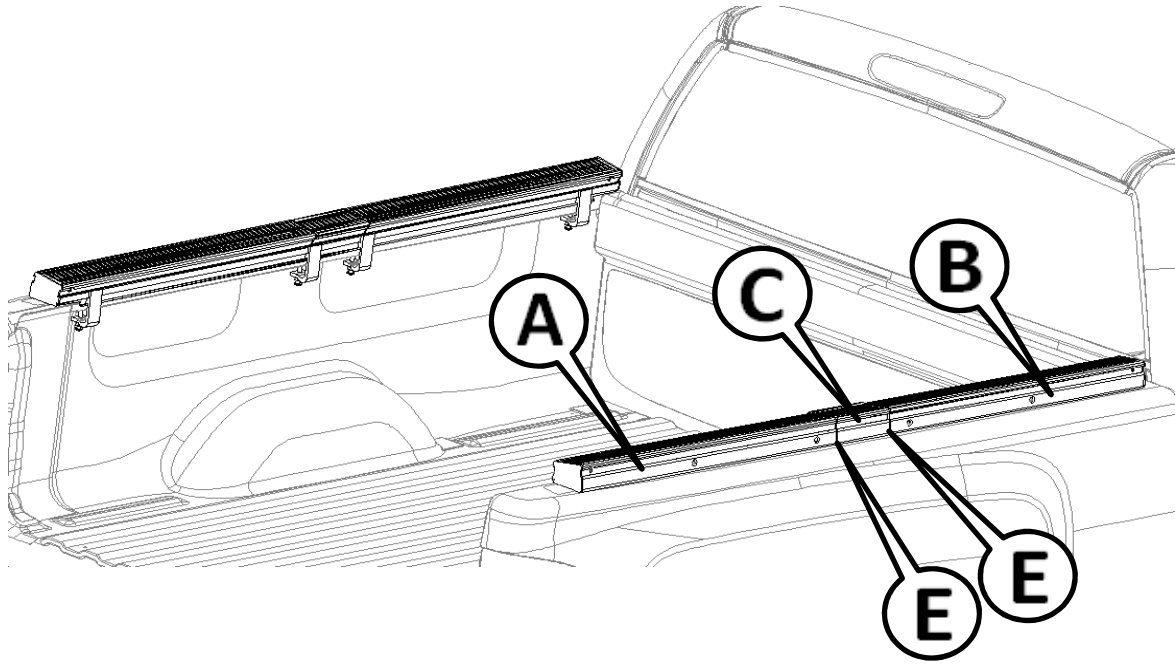

9

To use the Invis-a-rack, pull up on the top section using the cut out provided.

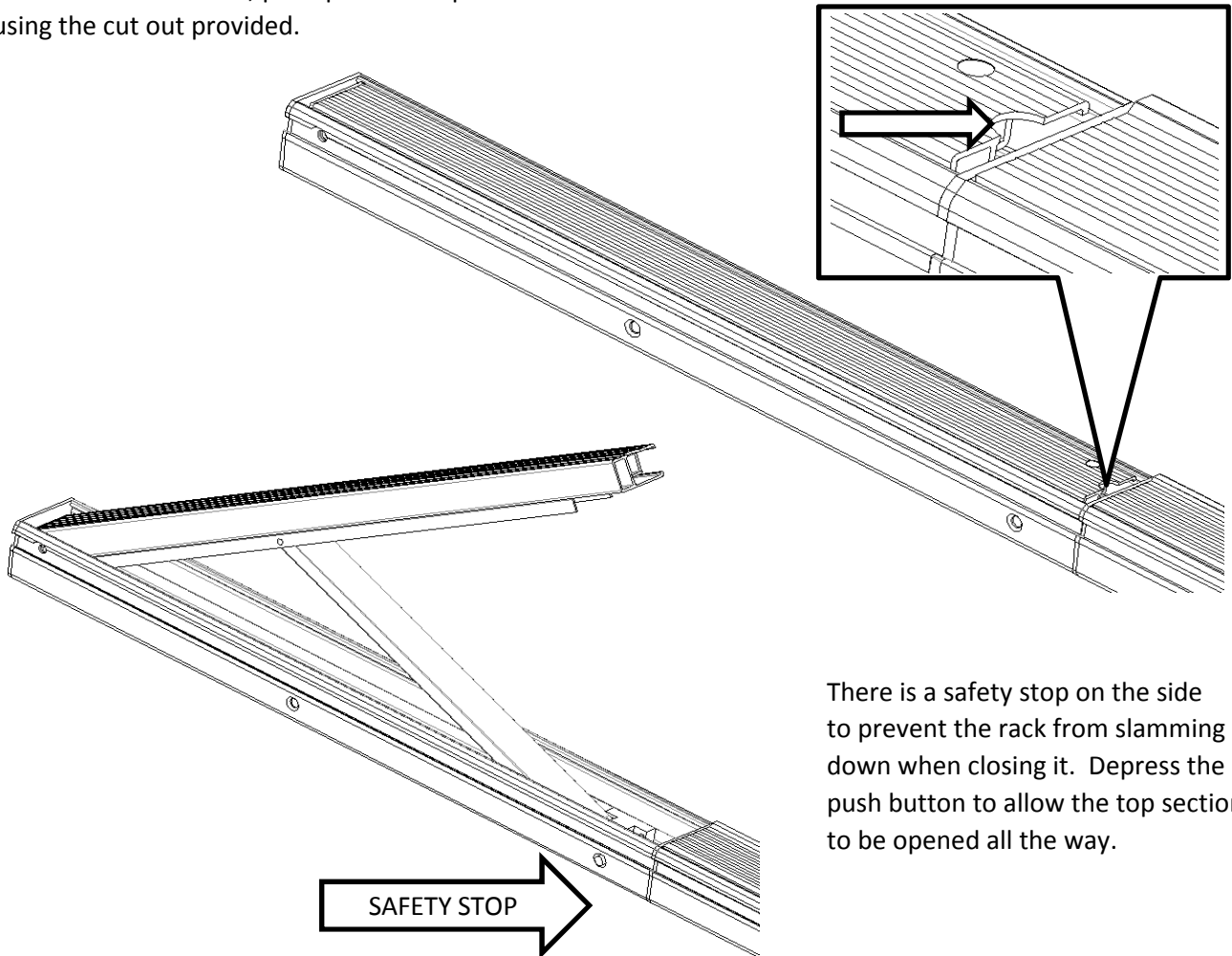

There is a safety stop on the side to prevent the rack from slamming down when closing it. Depress the push button to allow the top section to be opened all the way.

10

Extend the top section until the spring button engages the second hole on the side.

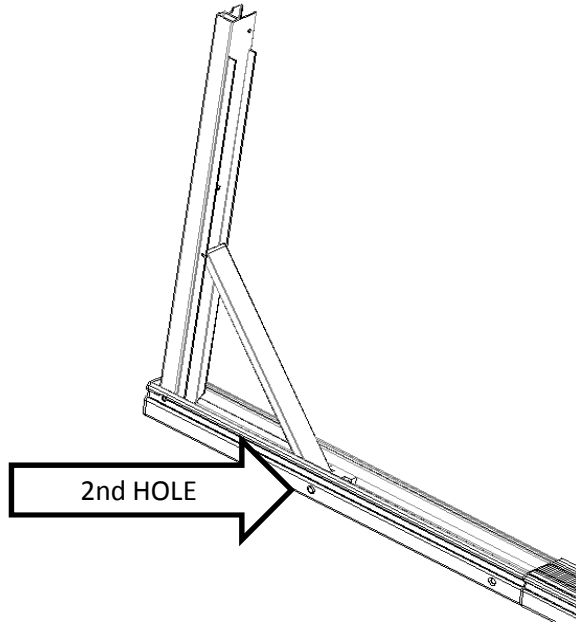

11

On the inside of the top section, pull up on the material arm. Extend the material arm until the push button engages the push button hole.

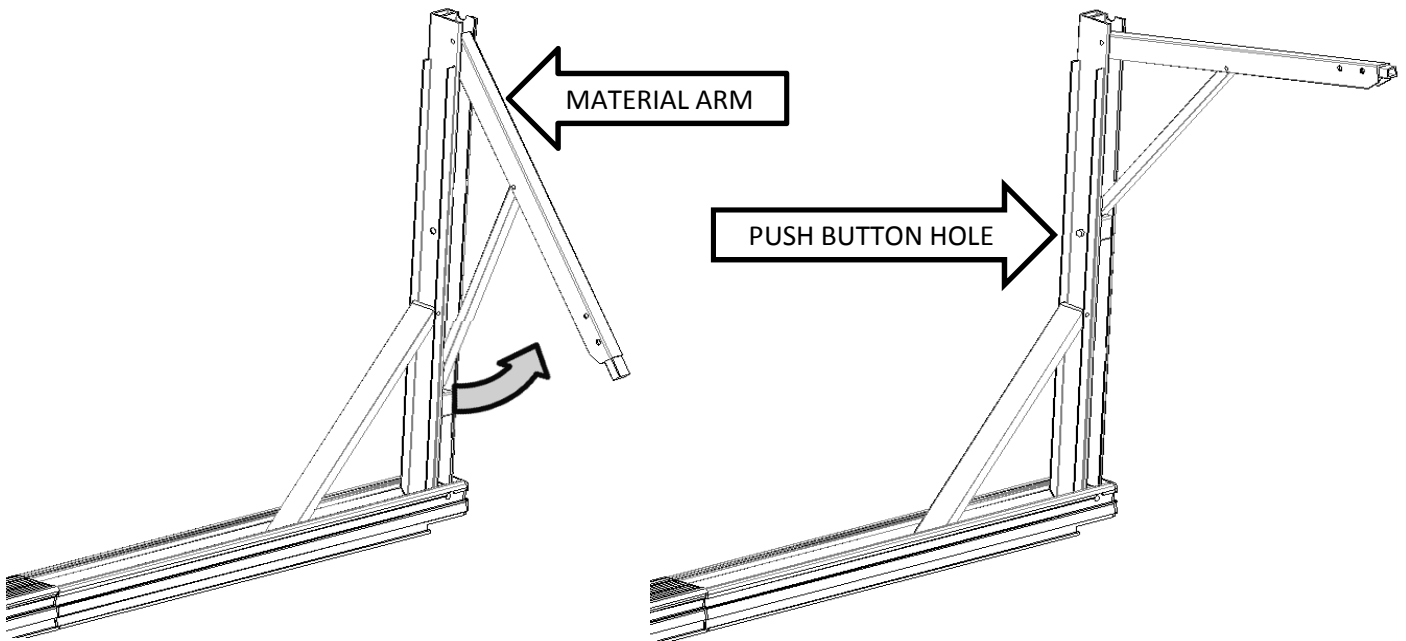

Repeat these steps for the other side.

12

Once both sides have been extended, press the push button in the cross bar and pull it out.

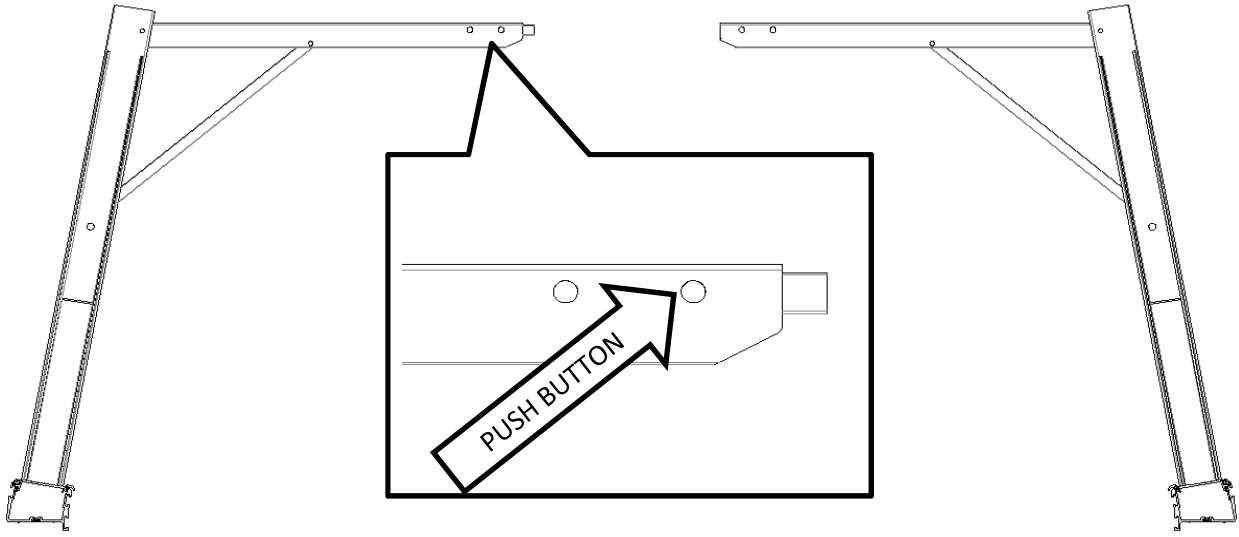

Insert the cross bar into the other side of the rack and engage the push button in the first hole.

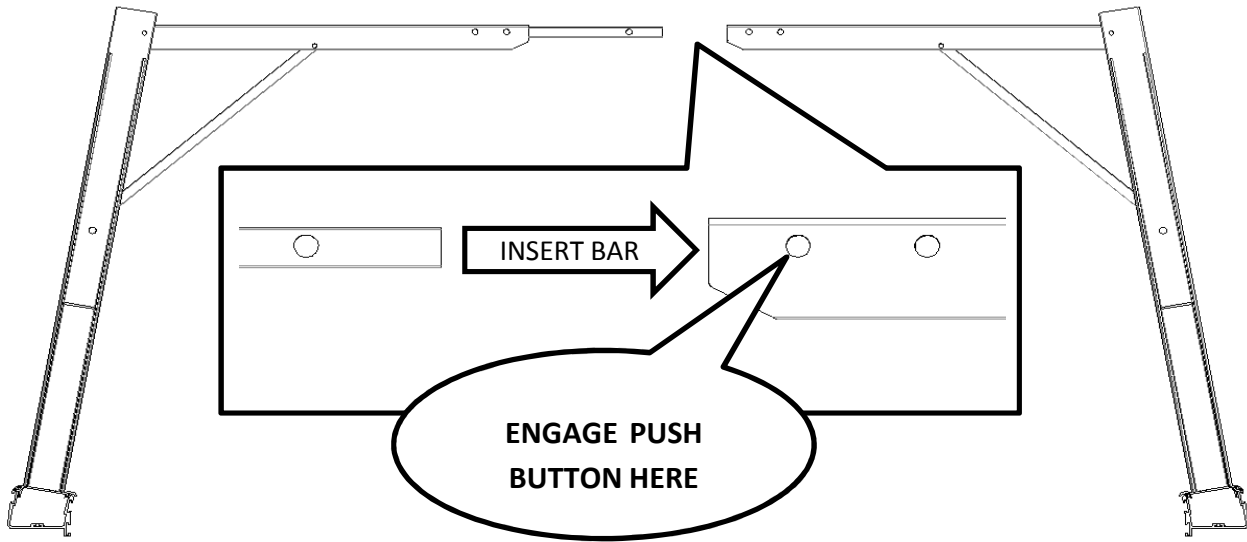

13

After engaging the push button, push the two halves of the rack apart, until the other push button engages. Do NOT use the rack with out both push buttons engaged.

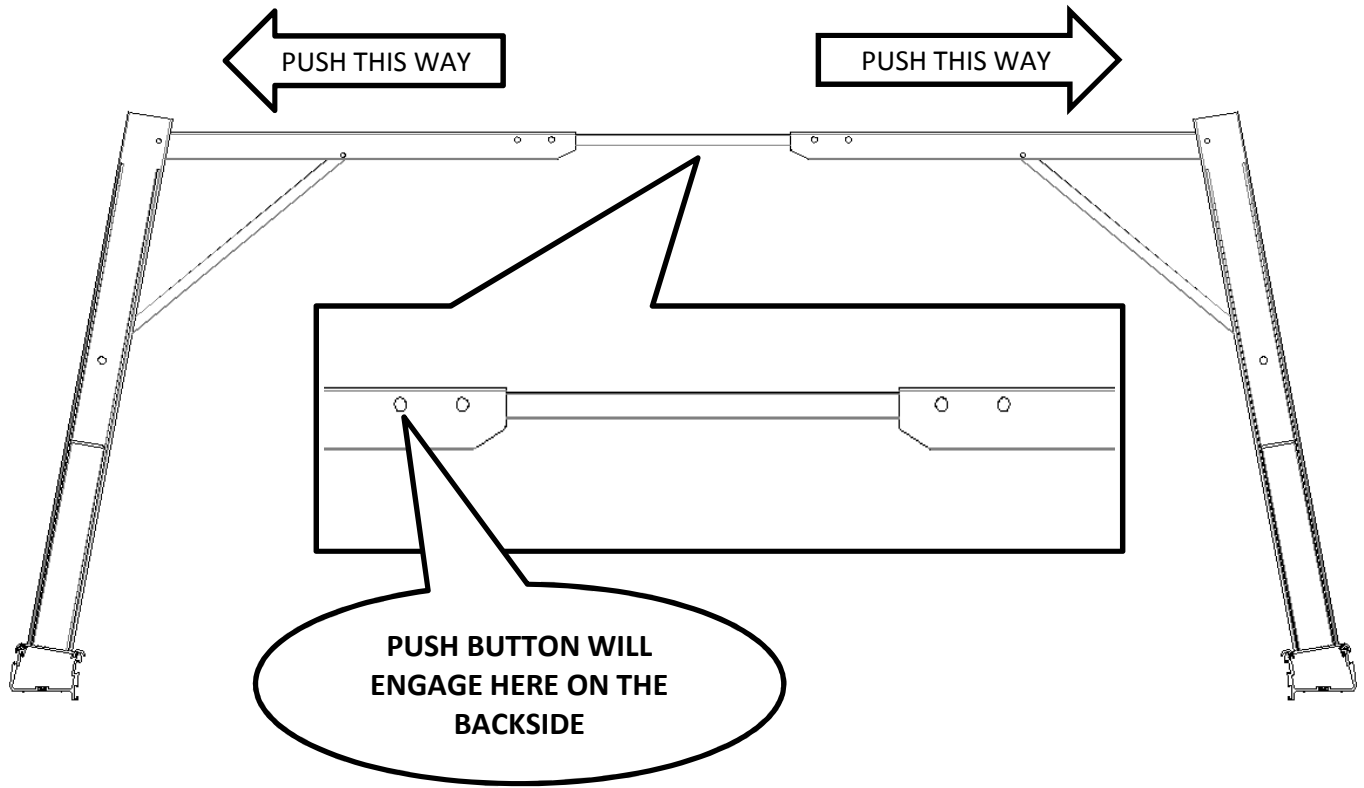

When installed on the Ford superduty, the second push button will engage the 2nd hole.

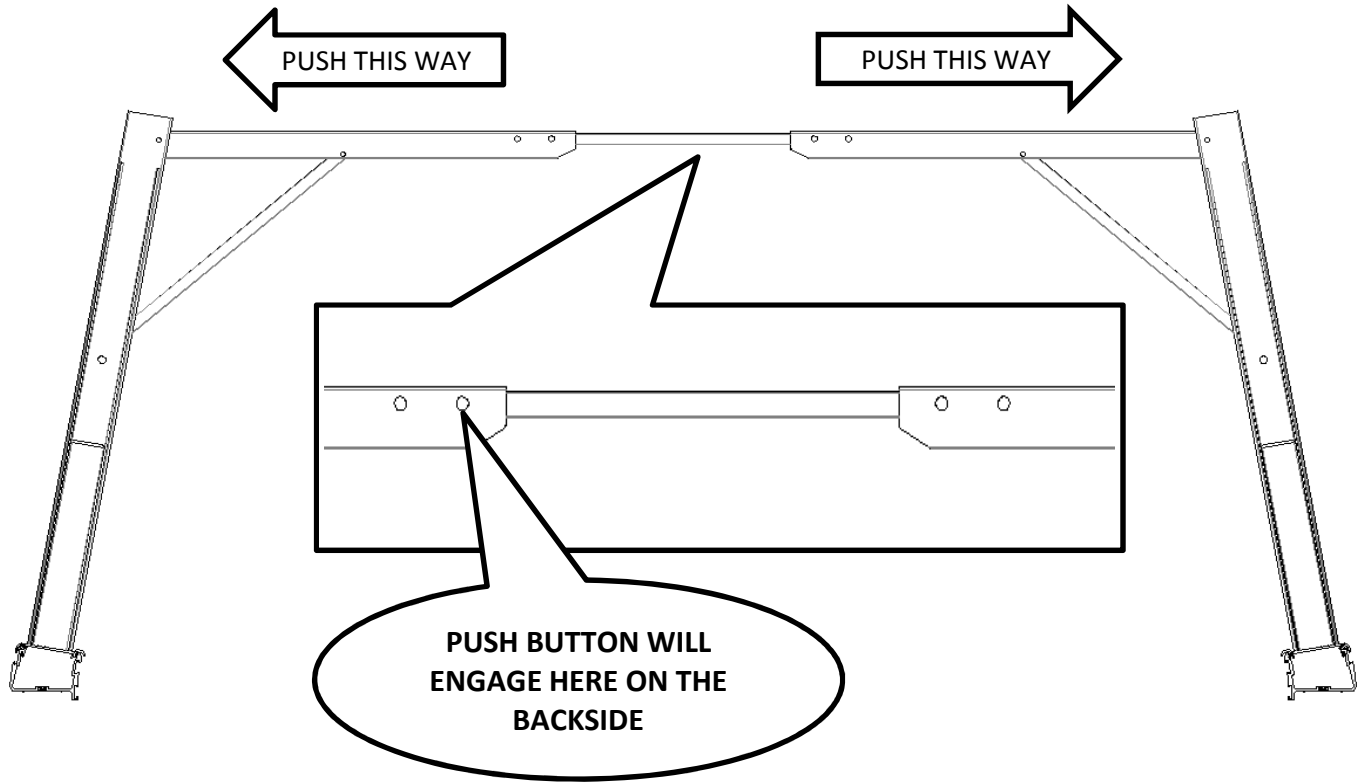

14

To stow the Invis-a-rack, depress the push button that was engaged in the previous step and pull the two halves of the rack towards each other.

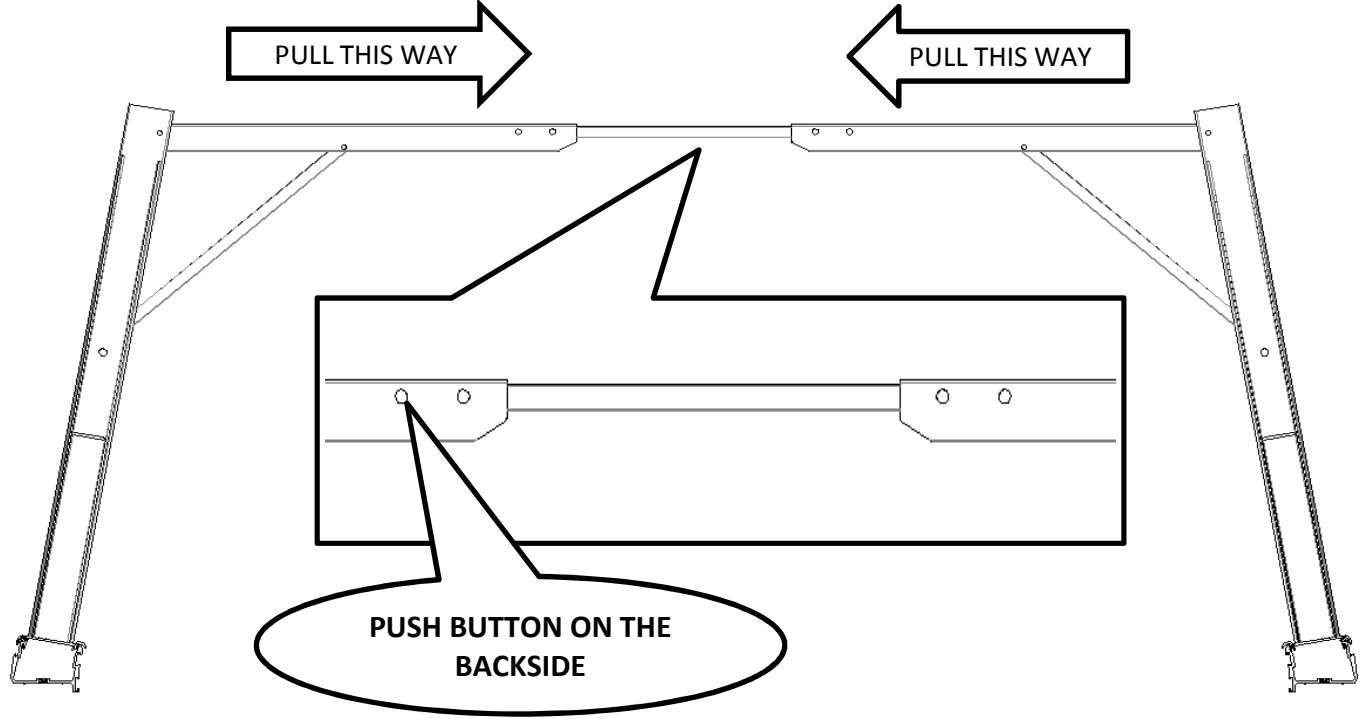

Disengage the other push button on the cross bar and slide it out.

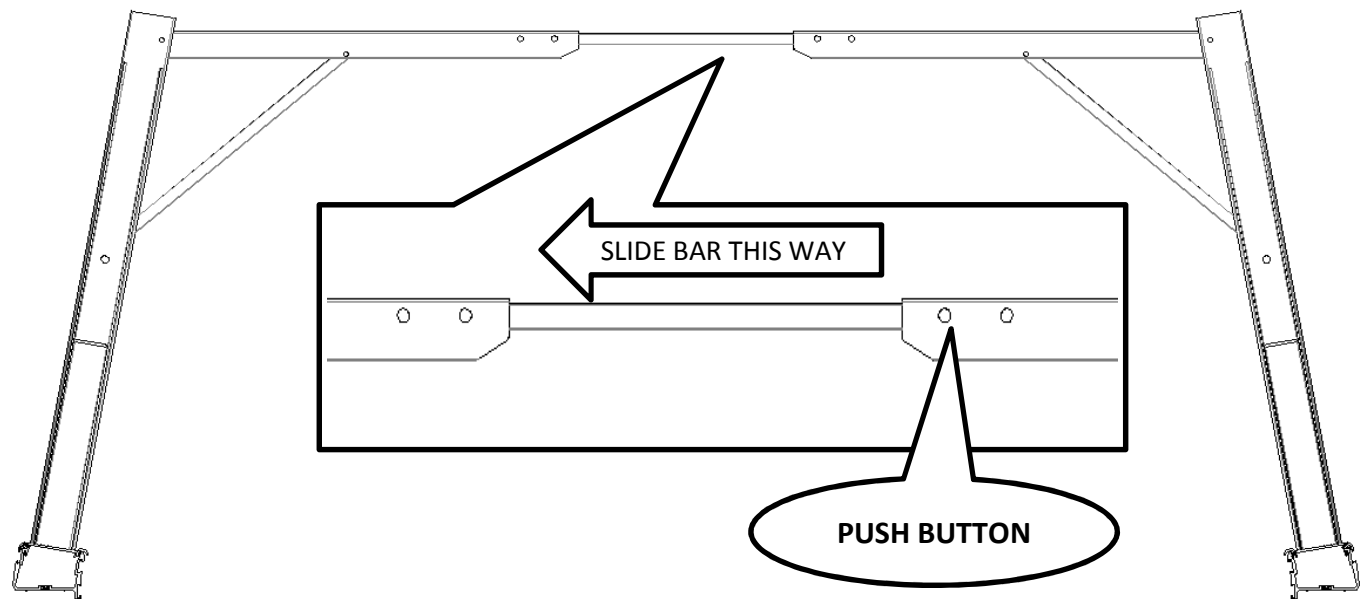

Slide the cross bar back until the push button engages in the first hole.

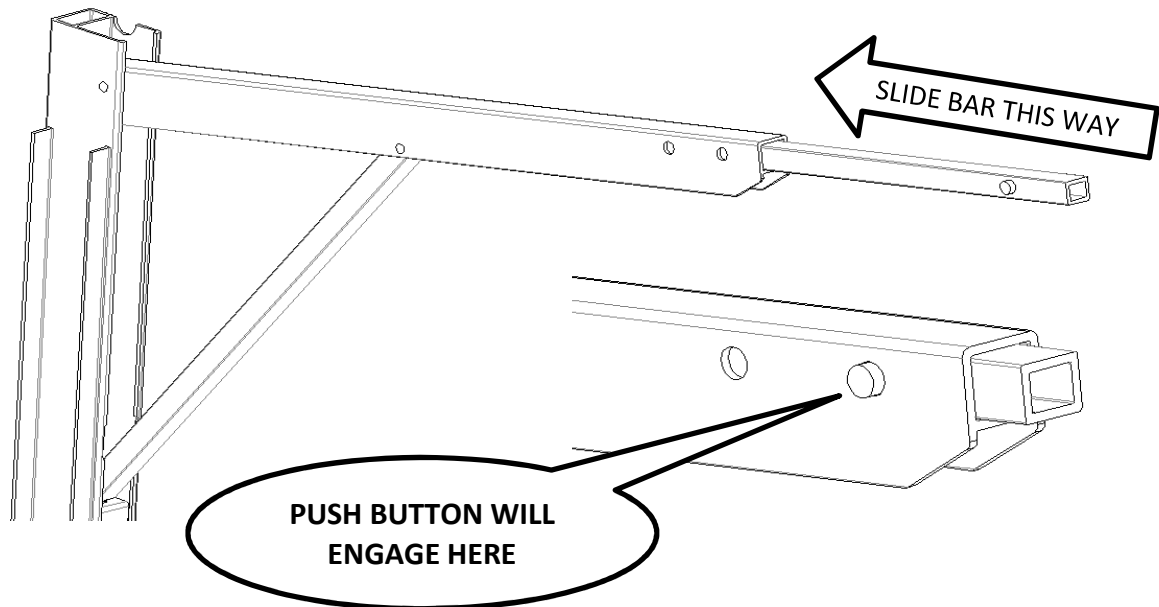

Depress the push button and bring the material arm down.

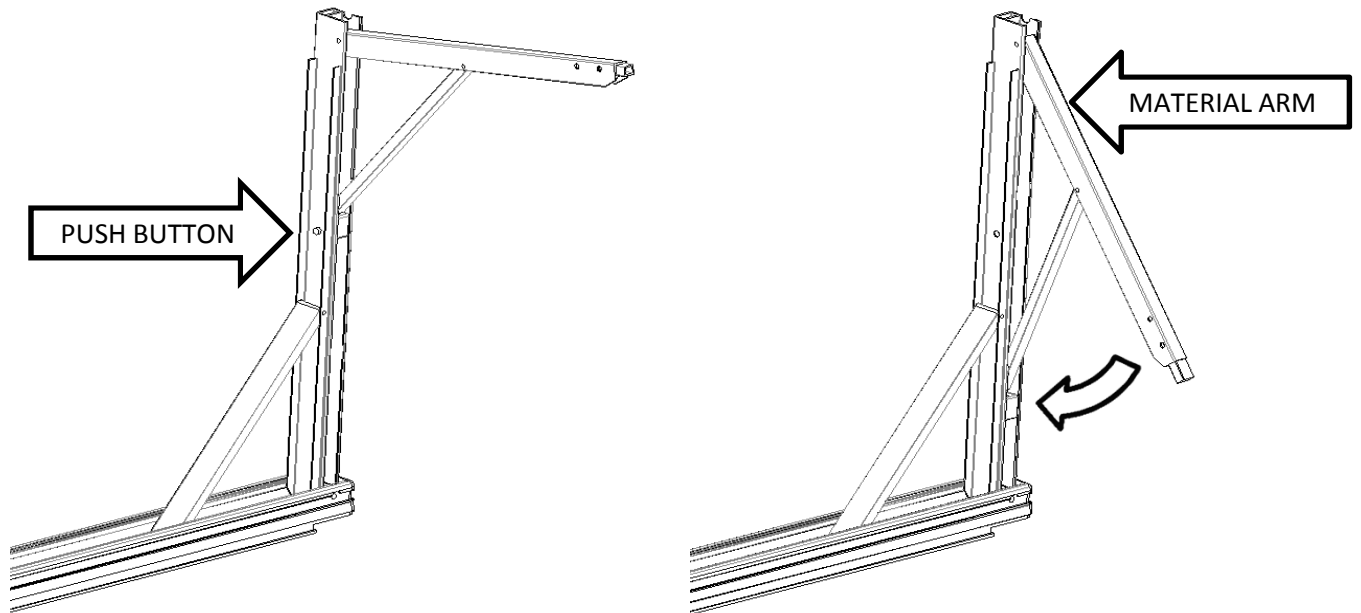

Depress the push button to lower the remaining part of the rack.
Then depress the push button in safety stop to complete the stowing of the rack.

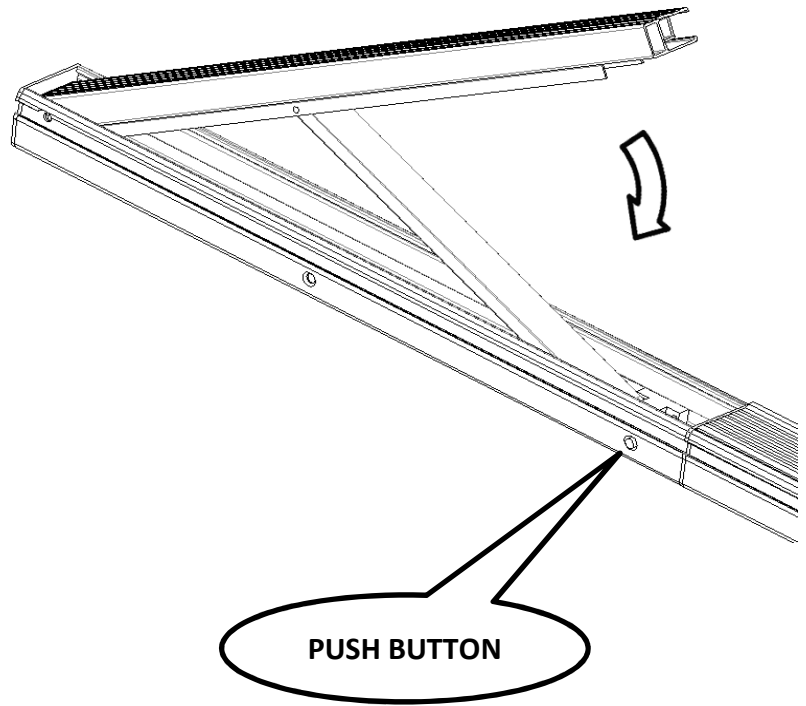
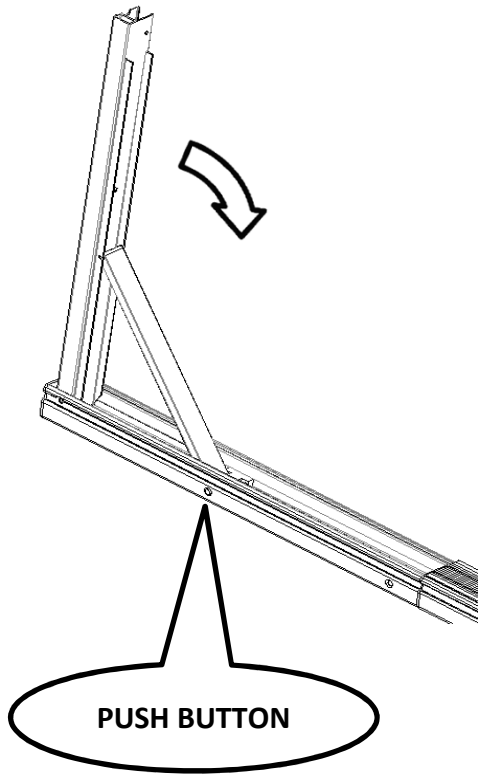

Repeat these step for the remaining portions of the rack.

To see a video showing the rack being put up, please use the QR code below.

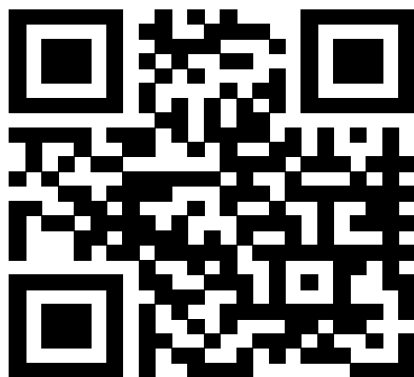

- * Review & assure understanding of all load, handling, operating limitations and safety messages contained in your Vehicle Owners Manual. Maximum Invis-a-rack load is 500 lbs. (evenly distributed & secured).
- * Ensure all fasteners & supports used to erect Invis-a-rack front & rear frames are fully engaged & secured. Inspect frequently and do not use Invis-a-rack if damaged or subjected to unintended overload.
- * Required set-up and stowage if Invis-a-rack involves pinch points where braces and cross pieces attach. Keep fingers clear and do not attempt to set-up or stow with load on Invis-a-rack.
- * **CAUTION! Hold down clamps must remain secured to support Invis-a-rack and load. Check often (particularly if rough road) and retighten as necessary. To avoid loss or damage to load & risks to others: NEVER USE HOLD DOWN CLAMPS AS ATTACHMENT FOR STRAPS OR OTHER MEANS OF SECURING LOAD. ALWAYS SECURE LOADS DOWN TO FACTORY (OEM) TIE DOWNS.**