

****DO NOT EXCEED RECOMMENDED VEHICLE TOWING WEIGHT!****

60612

GOOSENECK HITCH

1/30/2013

PAGE 1 OF 3

WARNING!! BRAKE, FUEL, AND ELECTRICAL LINES MAY NEED TO BE LOOSENED OR REPOSITIONED TO PROVIDE CLEARANCE FOR NEW HARDWARE. SOME MODELS REQUIRE MODIFICATION OR REMOVAL OF HEAT SHIELDS. ON SHORT BED MODELS, CHECK FOR ADEQUATE TURNING CLEARANCE BETWEEN THE FRONT OF ALL TRAILERS AND THE TRUCK CAB. ON TWO WHEEL DRIVE TRUCKS A CLEARANCE CHECK MUST BE PERFORMED WHEN TRUCK IS LOADED AND UNLOADED TO VERIFY THE INVERTED BALL WILL NOT INTERFERE WITH THE TOP OF THE DIFFERENTIAL

Hardware List			
ITEM	QTY	PART NUMBER	DESCRIPTION
1	2	60612-CLA	SAFETY CHAIN LOOP ASSEMBLY
1.1	1	60612-UB	5/8" - 11 x 2.50" x 3.25" U-BOLT
1.2	4	5/8"	WASHER WIDE
1.3	2	CM-C113-UBS	U-BOLT SPRING
1.4	2	5_8-11 NYLOCK HEX NUT	5/8"-11-2B UNC NUT
2	2	3/8"	WASHER
3	3	#10-32 x 3/4	FLAT HEAD C'SUNK CAP SCREW
4	1	#10-24 x 1.25 HHFS	HEX HEAD FLANGE SCREW
5	1	#10-24 NYLOCK HEX NUT	NYLOCK HEX NUT

Parts List			
ITEM	QTY	PART NUMBER	DESCRIPTION
A	1	60612-WA	GOOSENECK CENTER SECTION
B	1	60611-CL	CENTER LOCATOR / TRIM SHIELD
C	1	66165	RUBBER COVER
D	1	CM-C60-B	TURNOVER BALL COMPLETE
E	1	CM-C60-H	VINYL HANDLE GRIP
F	1	CM-C60-R	.375" HANDLE ROD
G	1	CM-C600-CR	3.75 DIA. x .375" CHROME RING
H	1	CM-C600-CLP	CAST LOCK PIN
I	1	CM-C60-CS	7.5 LB COMPRESSION SPRING
J	1	CM-UE1	.300" U-SHAPED EDGING

TOOLS REQUIRED
SAFETY GLASSES
EAR PROTECTION
RATCHET
8mm, 15/16" SOCKETS
8mm END WRENCH
DRILL
3/16" & 5/8" DRILL BITS
4" HOLE SAW
1/8" ALLEN WRENCH
CUTTING FLUID
RUST INHIBITOR

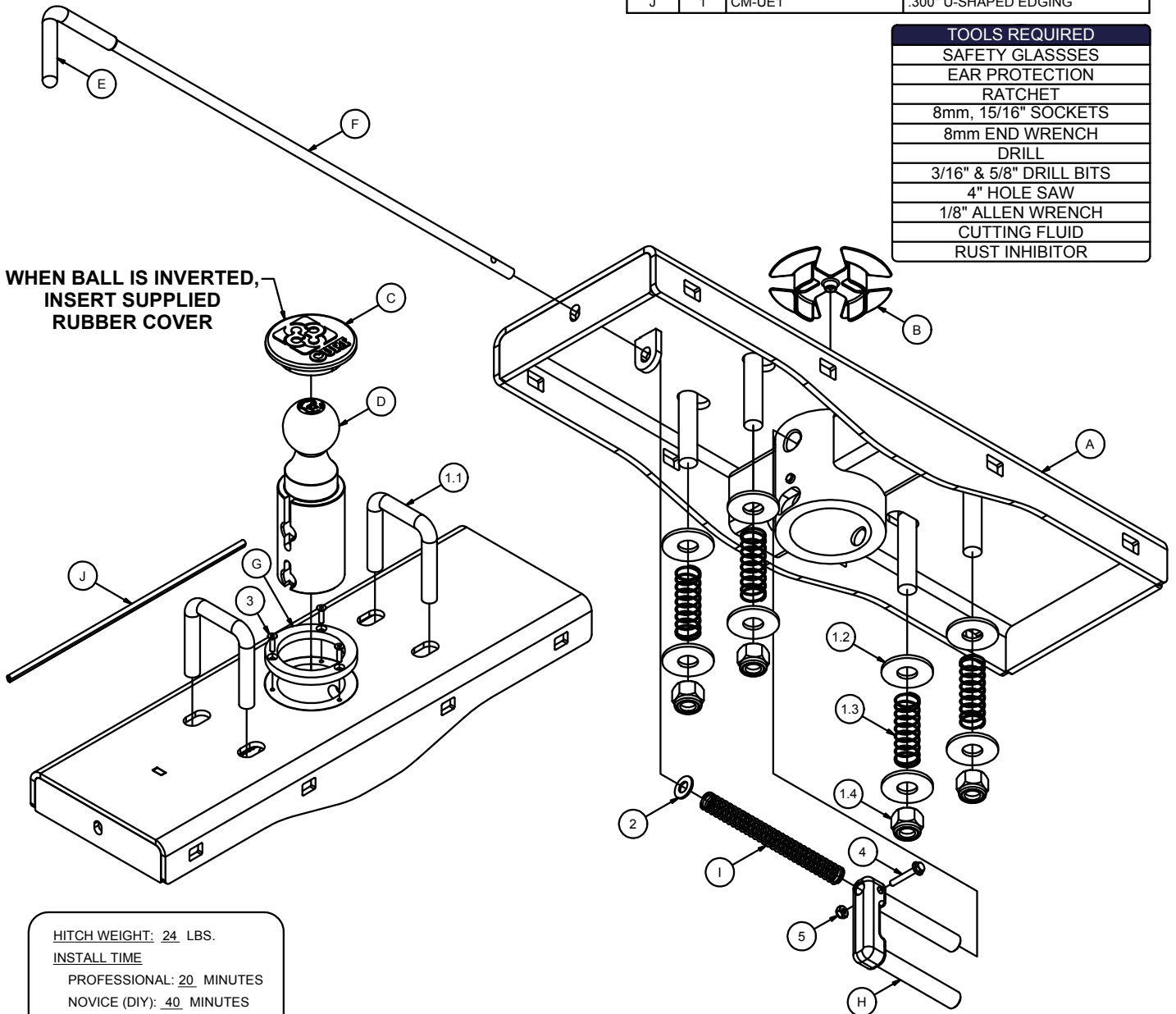

WHEN BALL IS INVERTED, INSERT SUPPLIED RUBBER COVER

HITCH WEIGHT: 24 LBS.
 INSTALL TIME
 PROFESSIONAL: 20 MINUTES
 NOVICE (DIY): 40 MINUTES

PERIODICALLY CHECK THIS GOOSENECK HITCH TO ENSURE THAT ALL FASTENERS ARE TIGHT AND THAT ALL STRUCTURAL COMPONENTS ARE SOUND.

Curt Manufacturing Inc., warrants this product to be free of defects in material and/or workmanship at the time of retail purchase by the original purchaser. If the product is found to be defective, Curt Manufacturing Inc., may repair or replace the product, at their option, when the product is returned, prepaid, with proof of purchase. Alteration to, misuse of, or improper installation of this product voids the warranty. Curt Manufacturing Inc.'s liability is limited to repair or replacement of products found to be defective, and specifically excludes liability for incidental or consequential loss or damage.

60612

GOOSENECK HITCH

PAGE 2 OF 3

WARNING!! BRAKE, FUEL, AND ELECTRICAL LINES MAY NEED TO BE LOOSENED OR REPOSITIONED TO PROVIDE CLEARANCE FOR NEW HARDWARE. ALL MODELS REQUIRE MODIFICATION OR REMOVAL OF HEAT SHIELDS. ON SHORT BED MODELS, CHECK FOR ADEQUATE TURNING CLEARANCE BETWEEN THE FRONT OF ALL TRAILERS AND THE TRUCK CAB. ON TWO WHEEL DRIVE TRUCKS A CLEARANCE CHECK MUST BE PERFORMED WHEN TRUCK IS LOADED AND UNLOADED TO VERIFY THE INVERTED BALL WILL NOT INTERFERE WITH THE TOP OF THE DIFFERENTIAL

INSTALLATION STEPS: (After subkit installation)

1. Drill pilot hole from underneath the truck bed through the hole in center locator / trim shield (B) using a 3/16" drill bit, see **FIGURE A**.
2. Drill four holes for safety chain loops from underneath the truck bed using a 5/8" drill bit. Use the center section (A) as a guide. Drill holes should go through the low rib sections, see **FIGURE B**. **NOTE:** Drill holes should be to the outside of slots in the center section on Ford models and to the inside of slots on Ram models, see **FIGURE A**.
3. Drill hole from top of truck using 4" hole saw, take caution to not drill through the center locator / trim shield (B). **NOTE:** The use of cutting fluid will ease this process. Remove the center locator by pulling it up through the hole.
4. Deburr cut holes and spray exposed metal with rust inhibitor. **OPTIONAL:** Insert rubber edging (J) around 4" hole.
5. Place chrome ring (G) into position and fasten with three flat head cap screws (3).
6. Place two U-bolts (1.1) down through the holes drilled in step 2.
7. From underneath the truck place a washer (1.2), a spring (1.3), a washer (1.2) and a 5/8" nut (1.4) on each of the four U-bolt legs. Tighten the nuts until flush with the bottom of the U-bolt, see **PAGE 1**.
8. Insert cast lock pin (H) into the ball cylinder with handle hole located on top.
9. Insert handle (F) from outside vehicle, through the holes center section, see **PAGE 1**. **NOTE:** Some models may require use of a pliers to bend the metal flange below the bed outward to allow the handle to move without interference.
10. Slide one 3/8" washer (2) and the compression spring (I) over handle before inserting the handle (F) into the lock pin (H). Insert handle into locking pin and secure with a hex head flange screw (4) and nylock nut (5), see **PAGE 1**. **NOTE:** If needed, add or remove a 3/8" washer (2) to ensure proper pull length of locking pin.
11. If removed, reinstall plastic wheel well covers. **NOTE:** Some models may require trimming of the plastic wheel well cover. Trim as needed for reinstallation and access to the handle. Reinstall spare tire.

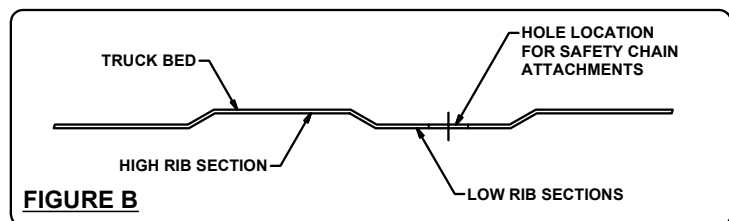
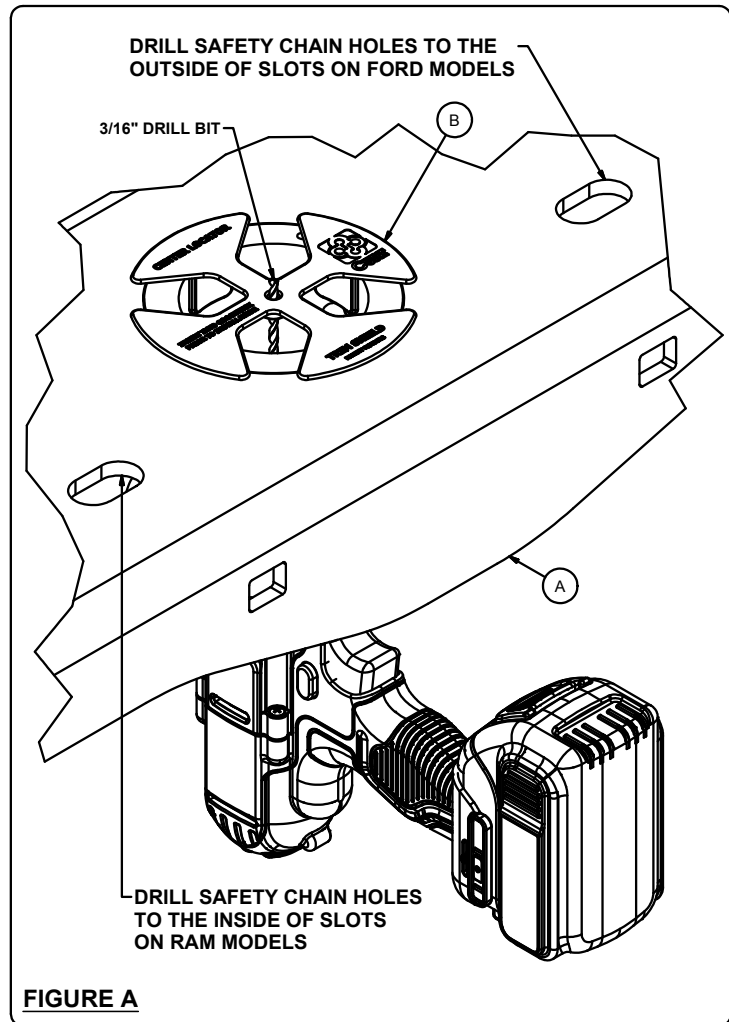

PERIODICALLY CHECK THIS GOOSENECK HITCH TO ENSURE THAT ALL FASTENERS ARE TIGHT AND THAT ALL STRUCTURAL COMPONENTS ARE SOUND.

60612

GOOSENECK HITCH

PAGE 3 OF 3

WARNING!! BRAKE, FUEL, AND ELECTRICAL LINES MAY NEED TO BE LOOSENED OR REPOSITIONED TO PROVIDE CLEARANCE FOR NEW HARDWARE. ALL MODELS REQUIRE MODIFICATION OR REMOVAL OF HEAT SHIELDS. ON SHORT BED MODELS, CHECK FOR ADEQUATE TURNING CLEARANCE BETWEEN THE FRONT OF ALL TRAILERS AND THE TRUCK CAB. ON TWO WHEEL DRIVE TRUCKS A CLEARANCE CHECK MUST BE PERFORMED WHEN TRUCK IS LOADED AND UNLOADED TO VERIFY THE INVERTED BALL WILL NOT INTERFERE WITH THE TOP OF THE DIFFERENTIAL

60612 OPERATION:

1. Place handle in the unlock position by pulling it out as far as possible and rotating it clockwise. **NOTE:** Never operate vehicle with the handle in the unlocked position.
2. Insert ball into the desired position in the cylinder by aligning the ball groove with the cylinder pin. If the groove and pin are not aligned simply rotate the ball until it drops into place.
3. Place handle in the lock position by rotating it counter clockwise until locking pin snaps back into position.

BEFORE TOWING THE FIRST TIME:

- Verify adequate turning clearance between the truck cab / box corners and trailer(s).
- Check truck box clearance. There should be a minimum clearance of 6" between the bottom of the trailer(s) overhang and the top of the box sides.
- Verify the inverted ball will not interfere with the top of the differential when hauling heavy loads. This is especially important on two wheel drive models.
- Verify all hardware is torqued to the proper specification.
- Verify the trailer safety chain length. Too much slack in the chain may prevent maintaining control in the event of separation. Leave only enough slack to allow full turning without interference.
- Verify the trailer attachments to the safety chain loops are secure (cannot be shaken free during towing).

BEFORE TOWING EVERY TIME:

- Ensure all fasteners are tight and that all structural components are sound. **NOTE:** Do not tow trailer with worn or damaged parts.
- Attach trailer securely to both of the safety chain loops.
- Ensure the handle is in the lock position and that the locking pin passes completely through the ball and both walls of the hitch cylinder.
- Ensure the trailer weight does not exceed any part of your towing system. Be sure load is heavier towards front of the trailer while not exceeding the hitch tongue weight. Be sure trailer load is secured to prevent shifting and centered from left to right. **NOTE:** Never load the trailer heavier behind the trailer axle(s).
- Check trailer tires to ensure they are inflated to the proper specification.
- Verify trailer lights, electric brakes and breakaway switches are working properly.

MAINTENANCE:

- Keep hitch ball, cylinder and trailer coupler lubricated regularly. Use silicone spray or equivalent to prevent wear / rust.
- Keep hitch assembly and trailer coupler free of dirt and other foreign debris.

WARNING!!

- Vehicle performance (braking, handling, acceleration, turning radius) can be drastically affected by the trailer. Allow additional time / space for stopping, changing lanes, passing and turning.
- Do not tow more than one trailer at a time. This may cause loss of control.

PERIODICALLY CHECK THIS GOOSENECK HITCH TO ENSURE THAT ALL FASTENERS ARE TIGHT AND THAT ALL STRUCTURAL COMPONENTS ARE SOUND.