

FREIN ÉLECTRIQUE / ELECTRIC BRAKE

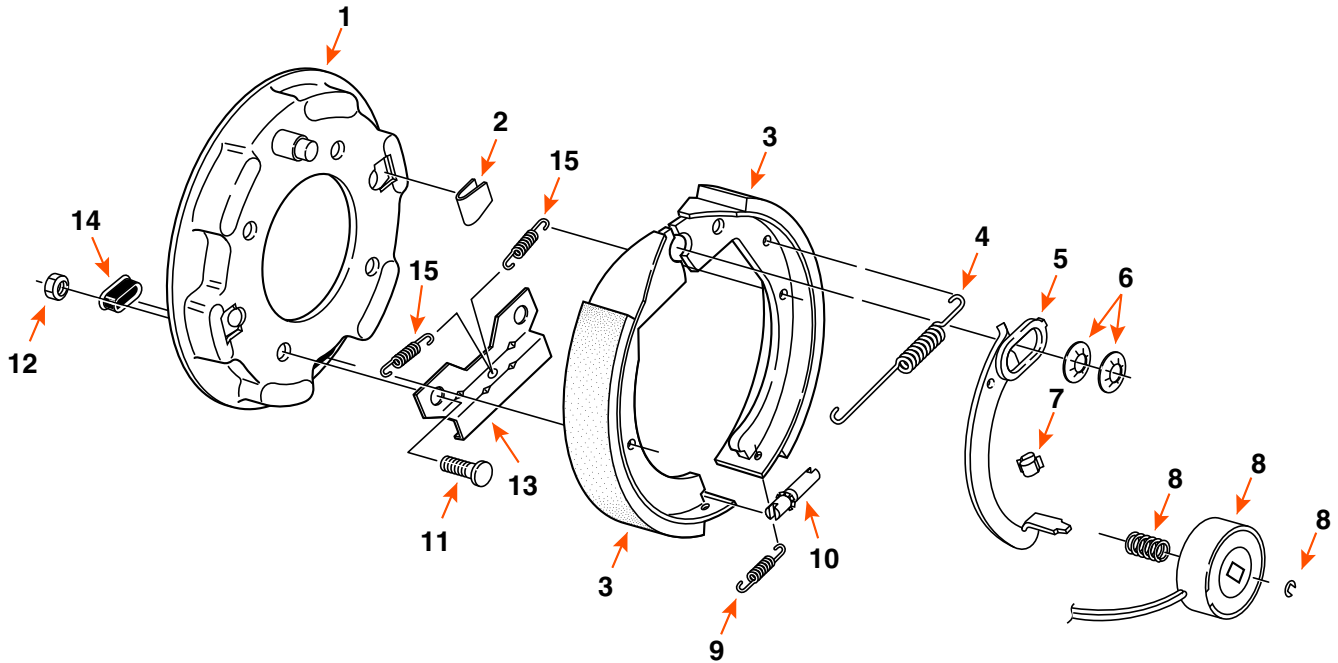

DIMENSION	CAPACITÉ CAPACITY	CÔTÉ SIDE	MARQUE BRAND
7" X 1 1/4"	2,2K	GAUCHE / LEFT	

COMPOSANTE COMPONENT	DESCRIPTION	QUANTITÉ QUANTITY	DEXTER	FRAMECO
2	AGRAFE DE RÉTENTION / SHOE HOLD DOWN CLIP	1	46023	-
3	BANDE DE FREIN / BRAKE SHOE KIT	1	20105107	-
4	RESSORT DE RETOUR / RETRACTOR SPRING	1	4624	-
5	LEVIER ACTIF / ACTUATING LEVER ARM	1	47114	-
6	BARRURE D'ÉTOILE / ANCHOR POST CLIP	2	4630	-
7	SUPPORT DE FIL / WIRE CLIP	1	275	-
8	AIMANT / MAGNET KIT	1	20113	-
8	RESSORT D'AIMANT / MAGNET SPRING	1	4682	-
8	BARRURE D'AIMANT / MAGNET RETAINER CLIP	1	4639	-
9	RESSORT D'AJUSTEMENT / ADJUSTING SCREW SPRING	1	4622	-
10	VIS D'AJUSTEMENT / ADJUSTING SCREW	1	20111	-
11	GOUJON À PRESSER 7/16" X 7/8" PRESS-IN STUD	4	7041	-
12	ÉCROU 7/16"-20 NF NUT	4	-	2093*
13	SUPPORT DE STABILISATEUR / STABILIZER BRACKET	1	64001	-
14	BOUCHON D'AJUSTEMENT / ADJUSTER PLUG	1	467	-
15	RESSORT DE CENTRAGE / SHOE CENTERING SPRING	2	46114	-

* ITEM VENDU SÉPARÉMENT / ITEM SOLD SEPARATELY